

SCHROEDAHL

A subsidiary of **CIRCOR** International Inc.

Series SUL

Automatic Recirculation Valve
for pump protection



Series SUL

Automatic Recirculation Valve
for pump protection

Preamble

Modern processing industry often requires centrifugal pumps to operate with fluctuating flows. This is because of automated control of such processes. When flows are too low in centrifugal pumps, however, this may result in overheating and lead to damage or cause unstable operation. It is important that flows through a pump do not fall below a certain minimum as stated by the pump manufacturer. The SUL valve is a reliable and economic solution.

Features

- Dependable operation
- Low maintenance
- Easy to install
- Damping of system pulsations
- Suitable for many kinds of media
- Wide temperature range



Besides the well-known TD series, the SUL series offers an effective, low-cost protection for pumps in the power, chemical and petrochemical industries.

Automatic Recirculation Valve

During the last decades, SCHROEDAHL has developed a series of valves, which provide automatic bypass at low flow conditions. The bypass opens only when the mainflow is throttled to less than the minimum flow. In these valves, which are basically disc-type non-return valves, the movement of the disc is used to open or close the bypass.

All valves combine 4 functions in 1

1. Flow sensitive:
The Automatic Recirculation Valve senses the main flow and positions the disc accordingly.
2. Automatic recirculation flow:
The Automatic Recirculation Valve bypasses the minimum flow to the suction tank (or to the condenser), preventing overheating of the pump.
3. High pressure reduction:
The cascade element in the bypass reduces the high pressure of the main flow to a lower pressure in the suction tank; this is combined with a low noise level and minimum wear and tear.
4. Non-return function:
The Automatic Recirculation Valve also operates as a check valve, preventing reverse flow through the pump.

Description

The SUL valve design is a further development of the SCHROEDAHL SU valve, an Automatic Recirculation Valve that has been used in ships since 1960. The valve consists of a valve body (item 01, 02), and a check valve (item 07), which is guided at the top by the guide bushing (item 04) and the vortex bushing (item 10) at the bottom. The check valve is springloaded (item 06) and is fitted with a damping device (item 14, 15).

This arrangement ensures a stable operation of the valve, even if pulsations occur in the system.

The automatic bypass section comprises the vortex bushing (item 10), in which a bushing/stem assembly (item 11/12) follows the movement of the check valve.

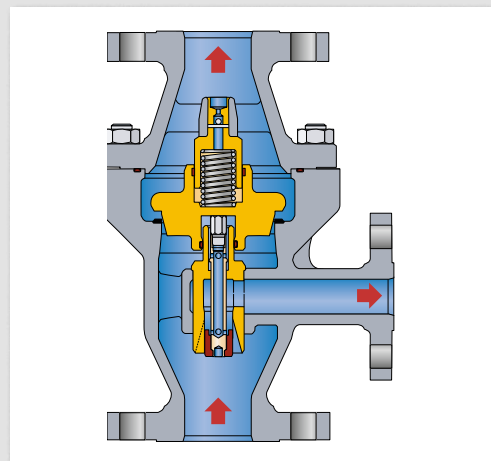

Features

Features

- Dependable operation – only a few moving parts.
- Easy to install – in a vertical or horizontal position, directly on the pump outlet.
- Easy to change flow characteristics (change of 1 part - item 13 - only).
- Suitable for a wide range of media, such as water, oils, hydrocarbons, liquid gases and chemicals.
Permissible temperatures from -200°C to +200°C.

Sizes

DN 25, 32, 40, 50, 65, 80, 100, 125, 150, 200 and 250 (1", 1¼", 1½", 2", 2½", 3", 4", 5", 6", 8" and 10") Larger sizes are available on request.

Materials

Body made of cast carbon steel or stainless steel, internal parts are all made of forged stainless steel.

Connection

Flanges acc. EN 1092-1, PN 10, 16, 25, 40 and 63 or ASME Class 150/300.

Sizing

1. Determine size of the valve with table 2.
2. Calculate the bypass pressure differential at minimum flow: $\Delta p = p_M - p_{bypass} \leq (\text{max. } 40 \text{ bar})$
3. Calculate the required bypass K_v or C_v

$$K_v = Q \text{ (m}^3\text{/hr)} \times \sqrt{\frac{\text{s.g.}}{\Delta p \text{ (bar)}}} \quad C_v = \frac{28}{24} \times K_v$$
4. Check if K_v or C_v required = K_v or C_v available according to table 2 (if not, select next larger valve).
5. Determine the required pressure rating, vertical or horizontal installation, and the type of flanges required.

Example

SUL083UV-CS is an Automatic Recirculation Valve type SUL with 2" main flanges, pressure Class 150, vertical installation, housing material made out of carbon steel.

Table 1: Valve code

Size	Pressure	Configuration
05 = DN 25 (1")	1 = PN 10	V = vertical installation
06 = DN 32 (1¼")	2 = PN 16	H = horizontal installation
07 = DN 40 (1½")	3 = PN 25 (Class 150)	CS = carbon steel body
08 = DN 50 (2")	4 = PN 40	SS = stainless steel body
09 = DN 65 (2½")	5 = PN 63 (Class 300)	D = with drainhole
10 = DN 80 (3")		U = ASME-flanges
		F = EN 1092-1 flanges

SUL in size DN 40/ PN 63 not available with EN flanges

Installation and Maintenance

Installation instructions

The valve should be installed as close to the pump as possible; preferably on the pump outlet and in a vertical position; horizontal installation is also possible. The distance between valve inlet and pump outlet should not exceed 3 m to prevent pressure pulsations caused by the elasticity of the medium. Ensure that the drain screw (if provided) is at the bottom of the valve in case of horizontal installation.

Maintenance

Correct operation of the valve is to be checked with the usual operational test of the pump. By throttling the valve in the main discharge piping the flow is reduced, thereby opening the bypass.

Notice: With warm fluids the bypass piping will warm up. Dissassemble and clean the valve once a year. As the seals harden during operation they should be replaced with new ones every time the valve is serviced.

Table 2: Spare parts

Item	Description
01	Lower Body
02	Upper Body
04	Guide bushing
06	Spring
07	Disc
10	Vortex Bushing
11	Control Bushing
12	Stem
13	Adjustment Bolt
14	Pin
15	Ball
25*	Drain Screw
26	Hex. Screw
30	O-Ring
31	Guiding Ring
32	Guiding Ring

■ Recommended spare parts. Other materials upon request.
*Drain screw, if required (optional)

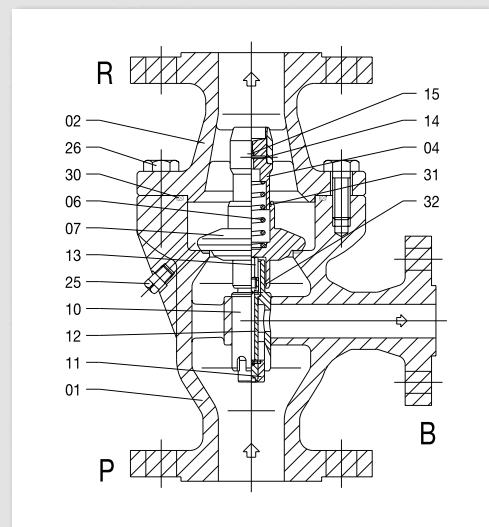

Drain screw item 25 is optional.

Dimensions

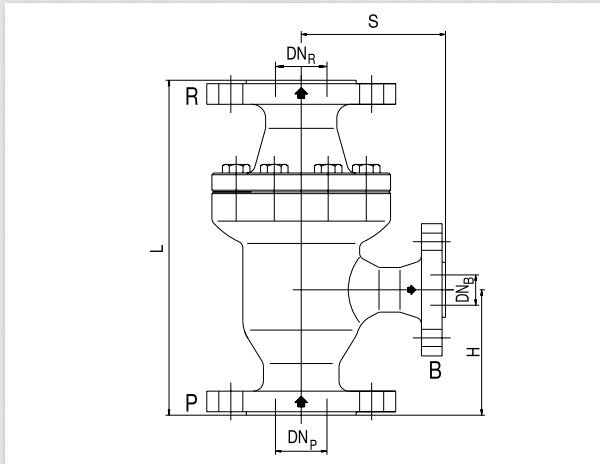

P= Pump outlet
 R= Pipeline process
 B= Bypass connection

Table 3: Dimensions

Valve size (DN _{PR})	Dimensions mm (in)				Weight (kg)	
	S	H	L	(DN _B)	PN 10/16 Class 150	PN 25/40/63 Class 300
25 (1")	115	102	267	15 (½")	12	18
32 (1¼")	115	102	267	20 (¾")	14	20
40 (1½")	115	102	267	20 (¾")	14	20
50 (2")	130	108	305	25 (1")	22	26
65 (2½")	165	136	406	40(1½")	46	51
80 (3")	165	136	406	40(1½")	46	51
100 (4")	209	159	495	50 (2")	105	118
125 (5")	267	228	679	80 (3")	220	240
150 (6")	267	228	679	80 (3")	220	240
200 (8")	356	305	902	100 (4")	524	549
250 (10")	356	305	902	100 (4")	530	560

Table 4: Sizing and selection

Valve size	mm (inches)	25 (1")	32 (1¼")	40 (1½")	50 (2")	65 (2½")	80 (3")	100 (4")	125 (5")	150 (6")	200 (8")	250 (10")
Max. main flow	m3/hr	12	30	30	50	100	100	200	400	400	750	750
Max. bypass flow	KV	2	4	4	6	16	16	30	60	60	100	100
	m3/hr	6	8	8	18	42	42	65	180	180	280	280
bypass size	mm (inches)	15 (½")	20 (¾")	20 (¾")	25 (1")	40 (1½")	40 (1½")	50 (2")	80 (3")	80 (3")	100 (4")	100 (4")

*DN 15 at PN 63

Besides the SUL Automatic Recirculation Valve for pump protection we also manufacture the following products:

Series TD

Type TDC

Automatic Recirculation Valve for pump protection of descaling applications



Type TDL, TDM

Automatic Recirculation Valve for pump protection in general applications



Series MRM

Automatic Recirculation Valve for pump protection for nominal pressures up to 640 bar / Class 4500



Series MRK

Most recent development of our proved and tested TDM technology





SCHROEDAHL

A subsidiary of  CIRCOR International Inc.

SCHROEDAHL GmbH

Alte Schönenbacher Str. 4
51580 Reichshof-Mittelagger
GERMANY

Phone +49 2265 9927-0
Fax +49 2265 9927-927

www.schroedahl.com
schroedahl@circor.com