

SCHROEDAHL

we protect your business

Series TDL

Installation and
maintenance instructions



Content

1. Dangers and safety precautions	3
1.1 Danger to persons and materials	3
1.2 Avoid dangers	3
2. Description	4
3. Packing and marking	5
4. Assembly and disassembly	6
4.1 Installation at the jobsite	6
4.2 Disassembly of the TDL	6
4.3 Assembly of the TDL	7
4.4 Disassembly of the bypass section	7
4.5 Assembly of the bypass sections	8
5. Commissioning of the TDL	8
6. Maintenance instructions	8
7. Warranty conditions	8
8. Instructions in case of damages	9
9. Customer services	9
10. Attachments	11
10.1 Sectional drawing	11
10.2 Parts list	12
10.3 Datasheet	14
Notes	15

1. Dangers and safety precautions

Minimum flow valves have the same potential danger as pressure vessels. Therefore planning, installation, operation and maintenance shall be done according to the necessary safety precautions.

1.1 Danger to persons and materials

- The minimum flow valves should only be operated within their limits of design and layout
- No changes are to be made without our approval. Only use original spare parts
- Safety regulations, site regulations and installation safety precautions are to be followed
- Please follow the instructions as given in this installation-, maintenance and assembly instructions

1.2 Avoid dangers

- Maintenance of the Automatic Recirculation Valve shall only be done by trained personnel
- Before disassembly, the installation has to be shut off and the valve pressureless and cooled down
- Please make sure that these safety precautions can only be cancelled after ending the assembly of the valve
- Please be aware that also in a pressureless valve there might still be medium
- Wear protective clothing

2. Description

The SCHROEDAHL Automatic Recirculation Valve model TDL is applied in centrifugal pump systems in order to provide an automatic leak-off flow in case of low load conditions. The application range of the series TDL is, independent of the temperature, up to 40 bar.

The valve consists of an upper and a lower housing, each provided with a flange. The bypass housing, and as an option also the start-up housing, are located horizontally at the side of the valve. The valve trim comprises a check valve as also a control- and throttle section.

The valve protects centrifugal pumps, especially boiler feed pumps, against overheating, by maintaining, automatically, a minimum flow. At flows, lower than the required minimum flow the check valve activates, by means of a lever, a bushing, which in turn, opens or closes orifices in the control head allowing a flow to the suction tank, (or condensate tank) The opening characteristic is linear; the bypass flow increases when the check valve moves from its switch point further into its closing position. Because of the modulation bypass control, the sum of process flow and minimum flow remains approximately constant.

The check valve, shaped like a differential control piston and spring loaded, has such a high own frequency, that waterhammering is avoided. The check valve dampens pulsations because of its throttling effect on the mainflow and stabilises unstable pump characteristics in the partial load range.

The housing is made from forged steel and is provided with a chromium steel liner in the check valve area. All moving parts and guides consist of alloy steel which are compatible.

3. Packing and marking

The Automatic Recirculation Valve is shipped, depending on size, in an aluminium box (reusable), skid-carton or in a wooden crate.

The standard factory conservation is sufficient to protect the valve for a period of approx. 6 months (the stocking area should be dry and ventilated).

If special packing or conservation is required, this should be stated with the order. The valve nameplate is attached to every valve housing. Specific valve data are indicated on the valve nameplate as per sample below.

○	SCHROEDAHL-ARAPP GMBH&CO.KG	○
	51580 Reichshof-Mittelagger / Germany	
DN	<input type="text"/>	PN <input type="text"/> mat. <input type="text"/>
press.	<input type="text"/>	temp. <input type="text"/>
order	<input type="text"/>	<input type="text"/>
type	<input type="text"/>	year <input type="text"/>
○	Tel.:02265/99270	Fax:02265/9927927
		○

If spare parts are required, the following valve data should be provided with the inquiry (order):

production number K (stamped in valve body), valve model number and part number (check parts list).

4. Assembly and disassembly

The Automatic Recirculation Valve type TDL is usually installed vertically, with the mainflow upward, and directly on the pump discharge flange. The bypass housing is connected to the bypass piping (and the piping consequently to the feedwater tank or other tank), so that a recirculation flow will be possible. Other installation positions of the valve (horizontal, upside-down) are possible, if so ordered only! No special tools are required for the installation, assembly or disassembly of the valve.

4.1 Installation at the jobsite

In order to prevent damage to the flange finish and/or the bolts the complete valve should be installed in the piping free of tension/ stress. Before tightening the bolts with a torque wrench (torques as recommended by the factory!), please ensure that the machined flange surfaces and packing rings are clean.

4.2. Disassembly of the TDL

- Depressurize the system
- Remove the TDL from the piping system
- Disassemble the bypass housing (pos. 09.). Pull the bypass trim „L“ out of the assembly (carefully!)
- Apply a screwdriver between the collar of the control head (pos. 11) and the valve body (pos.01)
- Remove the upper body (pos.02) from the lower body (pos.01) by loosening the hexagon nuts (pos. 28)
- The check valve (pos.07) and spring (pos.06) can now be removed from the lower body (pos.01)
- Clean all parts and check for any damages
- In case of damaged seats (check valve seat or bypass seat), this should be repaired by lapping the respective parts on the seats. Replace the o-ring (pos.30)

4.3 Assembly of the TDL

- Replace the check valve (pos.07) with the spring (pos.06) in the lower body (pos.01)
- Now the upper body (pos.02) is placed on the lower body (pos.01) and the hexagon nuts (pos. 28) are tightened (check cross sectional drawing!)
- Carefully insert the bypass section „L“ in the valve body and ensure that the lever (pos. 13) fits (slides) in the slot in the check valve (pos.07)
- The bypass housing (pos.09) with the bypass orifice (pos. 23, 31, 36-38) is now carefully replaced and tightened to the housing (pos.01) with the hexagon nuts (pos. 29)

4.4 Disassembly of the bypass section

Occasionally, and because of contamination of the fluid, a complete disassembly of the bypass trim may be required. At each inspection the bypass should be checked for proper operation. In case of damages, the bypass section should be removed, disassembled and the damaged parts replaced.

Inspection:

- Check the contact area of the control head (pos.11) and the contact area of the control bushing (pos.16) for any damages
- When damaged, the controlhead and the control bushing should be replaced as an unit

Note:

- In case of doubt the complete bypass assembly (pos. 11, 13-16, 23, 31, 36-38) may be replaced and the disassembled bypass may be send to the factory for repair
- Replace the complete seal set

4.5 Assembly of the bypass sections

Proceed in the reverse order as per disassembly instruction above.

5. Commissioning of the TDL

The valve is commissioned together with the pump. When the main shut-off valve in the pump discharge piping (to the boiler or process) the specified bypass flow is maintained through the bypass section (and to the piping of the bypass system). By closing or opening the main shut-off valve, the opening and closing of the bypass can be checked. The switch point of the valve can be established acoustically (use a technical stethoscope or even a screwdriver to the ear will do). In case a manual start-up connection is provided on the valve, the minimum flow is achieved through this section. The automatic bypass is closed during commissioning and the manual start-up is opened. The automatic bypass section is spared (protected) during commissioning in this way, as the fluid might still be contaminated and/ or carry solids!

6. Maintenance instructions

The TDL has been designed in a special way so that no special maintenance is required. Maintenance is restricted to cleaning the trim together with the pump at regular intervals. After disassembly of the valve, all seals should be replaced (by new seals) before re-assembly of the valve.

7. Warranty conditions

If no special conditions have been agreed upon the order, the warranty is limited to 24 months after shipment or 8000 hours of operation. The warranty does not include damage caused by improper handling, dirt in the system or normal wear.

8. Instructions in case of damages

In order to judge the damages (and the cause), the following information is required:

- 1) The production number of the valve
i.e. K..-.... (Year of manufacturing / production no.)
- 2) Valve model type and size e.g. TDL DN..., PN...
- 3) A description of the system in which the valve is installed
- 4) Please use the datasheet, page 14, for communication of loaddata information

9. Customer services

In case information is required or in case of breakdown, the following organisation can be addressed:

SCHROEDAHL-Arapp
Spezialarmaturen GmbH & Co. KG
Sales international dept.
Schoenenbacher Str. 4
51580 Reichshof-Mittelagger
Germany

Phone: +49 2265 9927-0
Fax: +49 2265 9927-927

SCHROEDAHL International Corp.
2400 Augusta Dr., Suite 280
Houston, Texas 77057
USA

Phone: +1-713-975-8351
Fax: +1-713-780-0421

SCHROEDAHL offers advise, delivery, installation, commissioning, maintenance, repair and modification. Our customers are offered an extensive customer service, which is worldwide available, 24 hours a day.

Quality assurance of SCHROEDAHL valves is made according to the high quality requirements of German and international quality authorities.

We fulfill all requirements acc. DIN, UVV, VdTÜV, ADStandards, TRD and all international standards as ASME as well as DIN ISO 9001/EN29001.

Besides the Automatic Recirculation Valves we also have the following products in our programme:

- Control valves for powerplants and industrial applications
- Desuperheaters
- Strainers
- Adjustable pressure regulating valves for pressure reduction
- Flow actuated control valves for various applications

10. Attachments

10.1 Sectional drawing

P = pump end

R = pipeline end

B = bypass end

Installation P- R vertical

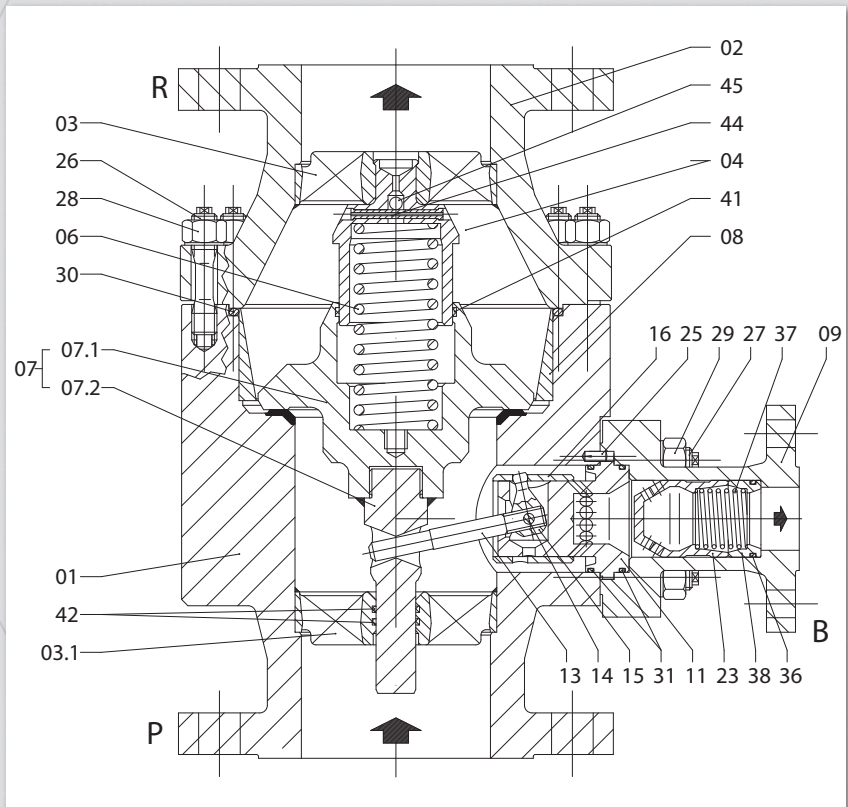

10.2 Parts list

Housing

Pos.	Description	Material		Recommended Spare parts
		CS	SS	
01	Lower body	1.0460	1.4404	
02	Upper body	1.0460	1.4404	
03	Valve stemguide	1.4405	1.4405	
03.1	Valve stemguide	1.4405 4)	1.4405 4)	
04	Guide bolt	1.4021	1.4021	
06	Spring	1.4310	1.4310	X
07	Check valve (assy.)	1.4404	1.4404	X
07.1	Check valve	1.4404	1.4404	
07.2	Stem	1.4404	1.4404	
08	Liner	1.4301	1.4301	
09	Bypass branch	1.0460	1.4404	
25	Guide pin	1.4305	1.4305	
26	Bolt	1)	1)	
27	Bolt	1)	1)	
28	Hexagon nut	2)	2)	
29	Hexagon nut	2)	2)	
30	O-Ring	3)	3)	X
40	Damper	4)	4)	
41	Guide-Ring	PTFE/ Carbon 4)	PTFE/ Carbon 4)	X
42	Guide-Ring	PTFE/ Carbon 4)	PTFE/ Carbon 4)	X

1) 8.8 to DN 150 PN 40, DIN 1.7709 from PN 63 and from DN 200 PN 10

2) 8 to DN 150 PN 40, W-Nr. 1.7258 from PN 63 and from DN 200 PN 10

3) EPDM, BUNA, VITON, FLUORAZ, CHEMRAZ, PTFE

4) Design with damper / standard from DN 150

Bypass

Pos.	Description	Material		Recommended Spare parts
11	Control head	1.4122	1.4122	X
13	Lever	1.4021	1.4021	X
14	Pivot pin	1.4301	1.4301	X
15	Crank arm	1.4122	1.4122	X
16	Control bushing	1.4122	1.4122	X
23	Bypass orifice	1.4122	1.4122	X
31	O-Ring	3)	3)	X
36	O-Ring	3)	3)	X
37	Spring	1.4310	1.4310	X
38	Ring	1.4122	1.4122	X

1) 8.8 to DN 150 PN 40, DIN 1.7709 from PN 63 and from DN 200 PN 10

2) 8 to DN 150 PN 40, W-Nr. 1.7258 from PN 63 and from DN 200 PN 10

3) EPDM, BUNA, VITON, FLUORAZ, CHEMRAZ, PTFE

4) Design with damper / standard from DN 150

10.3 Datasheet

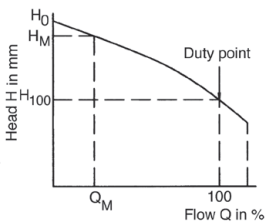
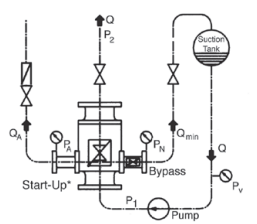
 SCHROEDAHL we protect your business		Automatic Recirculation Valve Technical Data		
Customer:	<input type="text"/>	Datasheet:	<input type="text"/>	
Enquiry no.:	<input type="text"/>	Quantity:	<input type="text"/>	
Prior reference:	<input type="text"/>		<input type="text"/>	
Order no.:	<input type="text"/>		<input type="text"/>	
Project:	<input type="text"/>		<input type="text"/>	
Automatic Recirculation Valve type: <input type="text"/>				
Valve inlet [in.]	DN <input type="text"/>	PN <input type="text"/>	Acc.: <input type="text"/>	
Valve outlet [in.]	DN <input type="text"/>	PN <input type="text"/>	Installation: <input type="checkbox"/> vertical <input type="checkbox"/> horizontal	
Bypass outlet [in.]	DN <input type="text"/>	PN <input type="text"/>	Paint: <input type="text"/>	
Start-up [in.]	DN <input type="text"/>	PN <input type="text"/>	Start-up <input type="checkbox"/> above <input type="checkbox"/> below checkvalve	
Mat. -/test certificates: <input type="text"/>				
Materials <input type="text"/>				
Housing:	Internals:	Seals:		
<input type="text"/>	<input type="text"/>	<input type="text"/>		
Medium	<input type="text"/>	Operating temp. [°C]:	<input type="text"/>	
S.G. [kg/m³]:	<input type="text"/>	Design temp. [°C]:	<input type="text"/>	
$Q_M =$ <input type="text"/> m³/h $Q_{100} =$ <input type="text"/> m³/h $Q_{max} =$ <input type="text"/> m³/h $Q_A =$ <input type="text"/> m³/h	$H_0 =$ <input type="text"/> m $H_M =$ <input type="text"/> m $H_{100} =$ <input type="text"/> m $H_{Qmax} =$ <input type="text"/> m $H_A =$ <input type="text"/> m	Suction pr. pv <input type="text"/> bar Differential pr. ($p_1 - p_v$) <input type="text"/> bar Backpress p_N <input type="text"/> bar Backpress p_A <input type="text"/> bar		
Notes: <input type="text"/>				
Revision	Date	Description	Name	Signature
<div style="display: flex; justify-content: space-around;"> <div style="text-align: center;">  <p>Head H in mm</p> <p>Flow Q in %</p> <p>Duty point</p> </div> <div style="text-align: center;">  <p>Start-Up* P_A P_N P_1 P_2 P_v</p> <p>Bypass Q_{min} Q</p> <p>Suction Q</p> <p>Pump</p> </div> </div>				

SCHROEDAHL

we protect your business

SCHROEDAHL-ARAPP

Spezialarmaturen GmbH & Co. KG

Schoenenbacher Str. 4

51580 Reichshof-Mittelagger

Germany

Phone +49 2265 9927-0

Fax +49 2265 9927-927

www.schroedahl.com

info@schroedahl.com

Schroedahl International Corporation

2400 Augusta Dr. Suite 285

Houston, Texas 77057

United States of America

Phone +1 713 9758351

Fax +1 713 7800421

sic@schroedahl.com